

Lithium-ion Battery Charger



Features

- Application: E-bike, E-scooter, E-wheelchair, E-tool
- CC/CV Charging Mode
- For 42V/10S Battery Pack Use
- Battery Polarity Reverse Protection
- LED Indicator
- Protections :
Short circuit / Over voltage / Over current
Over temperature
- No Load Power Consumption $\leq 1W$
- MTBF > 100,000 hours

EC1085 X Y - vv PP

- X:** AC inlet: 2. C8 3. C6
Y: Output range
vv: Specified output voltage, i.e. 42 is 42VDC
PP: DC plug type, i.e. Code 01 for 5.5x2.1mm or other options (refer to the appendix page)

General Specification

OUTPUT

For 10S battery pack use

MODEL No.	MAX. OUTPUT POWER (W)	OUTPUT VOLTAGE (Vo)	MIN. LOAD (Io)	MAX. LOAD (Io)	LOAD REGULATION	LINE REGULATION	RIPPLE & NOISE
EC1085XA	84W	42V	0A	2A	$\pm 5\%$	$\pm 1\%$	300mV
EC1085XB	42W	42V	0A	1A	$\pm 5\%$	$\pm 1\%$	300mV

NOTE:

- 1 : Ripple & Noise is measured by using 20MHz bandwidth limited oscilloscope and terminated each output with a 0.1uF ceramic capacitor & parallel with 47uF aluminum capacitor at full load and nominal line.
- 2 : Line regulation is defined by changing $\pm 10\%$ of input voltage from nominal line at rated load.
- 3 : Max. Power (W) $\geq V_o \times I_o$

INPUT

- Input Range 100 to 240 VAC
- Frequency 50 to 60Hz
- Input Current $\leq 2.2A$
- Inrush Current $\leq 70A/230VAC$

PROTECTION

- Short Circuit Protection Auto Recovery
- Over Voltage Protection Latch-off
- Over Current Protection Auto Recovery
- Over Temperature Protection Auto Recovery

ENVIRONMENT

- Operating Temperature -20 to 40°C
- Storage Temperature -20 to 85°C
- Operating Humidity 10% to 90%
- Storage Humidity 5% to 90%

MECHANICAL

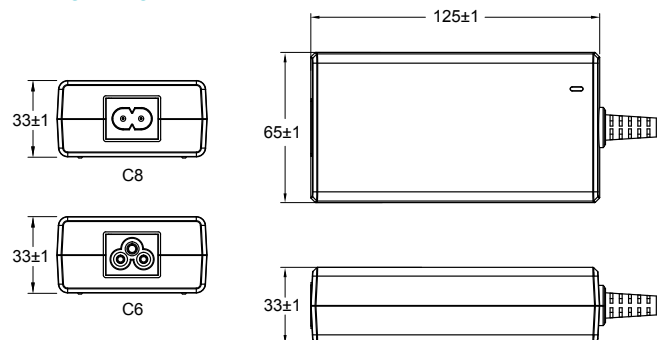

- Case Size: 125L x 65W x 33H (mm)
- AC Inlet: C8, C6
- Weight: 420g

SAFETY

- Certified for whole series: EN/IEC 60335-1/EN IEC 60335-2-29, FCC Part 15B, CE EMC(EN 55014-1+EN 55014-2), UKCA, Complied with UL 1012